

Biorealis Systems, Inc

P.O. Box 77-2773
Eagle River, Alaska 99577
(907) 694-6370
email: info@biorealis.com

Graywater Treatment Unit



Biorealis Systems, Inc has developed a simple modular wastewater treatment system designed specifically for smaller flows and off-grid use. It is capable of treating up to 100 GPD of domestic graywater or septic tank effluent to advanced water quality standards. It can be built for less than \$200 in commonly available materials (e.g. 55 gallon plastic drums, 5 gallon plastic buckets, PVC pipe and fittings, etc.) and a couple of weekends' worth of labor.

It is not intended to compete with the wide variety of currently available products designed to handle 400-500 GPD, but which cost as much as \$40,000

to install, require connection to 120 VAC power, and use between 2 and 10 KWH/day of electricity to operate.

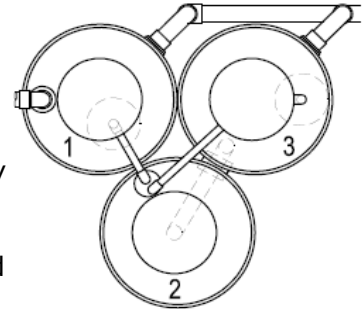

Design features include:

- **Modular:** Design consists of 3 different modules which can be combined in a variety of ways to treat a variety of different wastewaters to any desired quality.
- **Simple Design:** Can be locally built, using commonly available materials. Does not require specialized tools or skills to build, lends itself to local self-help solutions, creation of local jobs, small manufacturing business opportunities.
- **Low maintenance:** No moving parts to fail. Only non-corroding materials in contact with wastes. All modules and components easily assembled and disassembled.
- **Minimum energy use:** Less than 10 watts peak, less than 1/3 KWH/day. Suitable for use with off-grid, alternative energy sources.

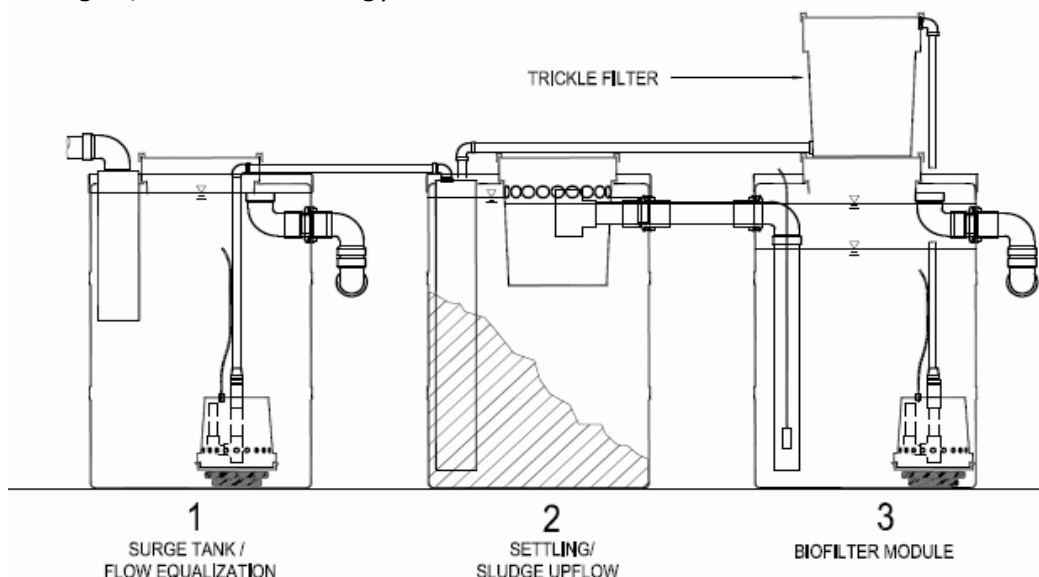

More information, including detailed drawings, construction photos, and a discussion forum are, or will be made available at <http://biorealis.com/biofilter/drumbiofilter/>